

# Soplantes tipo GKL-GSL

## Blowers type GKL-GSL



# GKL ATEX

## GKL ATEX

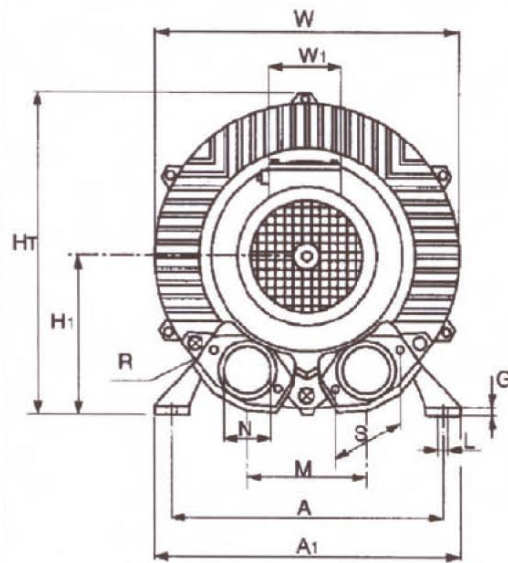
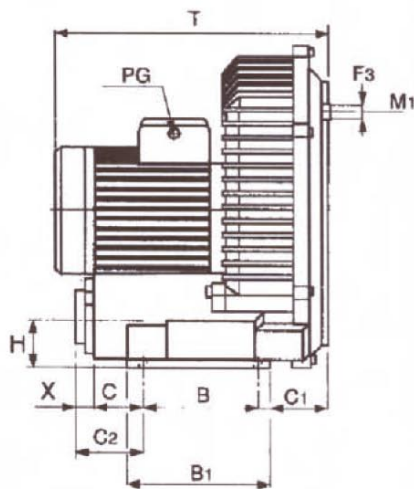
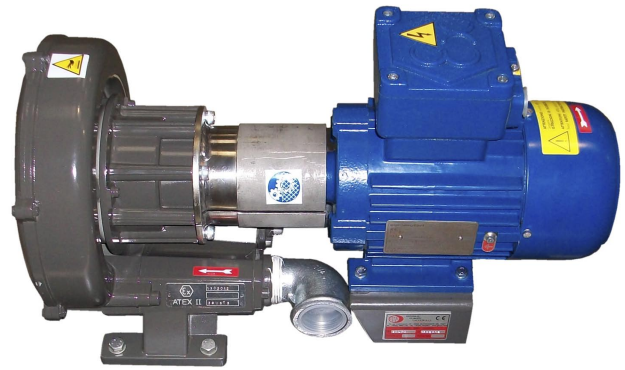

### GKL 1 etapa/GKL1 stage

		Tipo Type					
		GKL 30	GKL 70	GKL 100	GKL 130	GKL 250	GKL 400
Dimensiones (mm) Dimensions (mm)	A	205	205	225	260	290	365
	B	83	83	95	115	140	280
	A1	230	230	255	295	325	420
	B1	113	113	130	155	180	316
	W	196	238	287	327	375	490
	T	177	221	232	282	330	480
	HT	204	255	306	348	384	510
	H1	104	136	153	174	196	265
	L	9,5	9,5	12,0	12,0	15,0	15,0
	M	87	87	130	119	125	145
	N	1¼"	1¼"	1½"	1½"	2"	2½"
	C1	35	64	76	81	100	25
	C2	58	58	92	98	79	181
	R	5MA	6MA	8MA	8MA	8MA	12MA
	S	60	60	75	75	80	94
	H	39	39	49	48	52	81
	W1	71	83	83	83	83	122
	M1	108	140	188	200	261	408
	F3	5MA	6MA	6MA	8MA	8MA	12MA
G	10	10	14	13	13	15	

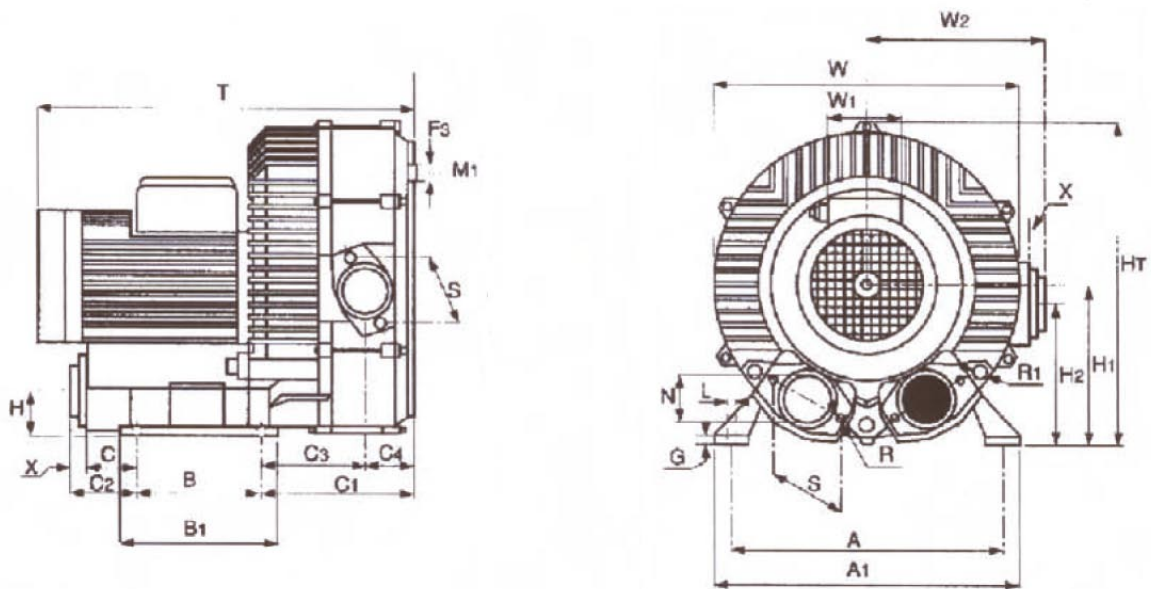

GKL 2 etapa tipo DV en serie/GKL 2 stage serie DV type

		Tipo Type					
		GKLDV 70	GKLDV 100	GKLDV 130	GKLDV 250	GKLDV 400	GKLDV 800
Dimensiones (mm) Dimensions (mm)	A	205	225	260	290	365	365
	A1	230	255	295	325	420	420
	B	83	95	115	140	280	280
	B1	113	130	155	180	316	316
	C	42	74	80	60	118	118
	C1	124	148	163	194	235	235
	C2	58	92	98	79	213	213
	C3	88	104	108	131	63	63
	C4	36	44	55	63	96	96
	F3	6MA	6MA	8MA	8MA	12MA	12MA
	G	10	14	13	13	15	15
	H	39	49	48	52	81	81
	H1	136	153	174	196	265	265
	HT	255	306	348	384	510	510
	H2	-	151	146	166	177	177
	L	10	12	14	15	15	15
	M1	140	188	200	261	408	408
	N	1¼"	1½"	1½"	2"	2½"	2½"
	R	8MA	10MA	10MA	10MA	12MA	12MA
	R1	6MA	8MA	8MA	8MA	8MA	8MA
	S	60	75	75	80	94	94
T	-	332	398	503	585	585	
W	238	287	327	375	490	490	
W1	83	83	83	83	122	122	
W2	-	181	195	220	253	253	
X	16	18	18	19	26	26	

DIAGRAMMA DI SELEZIONE COMPRESSORI/SOFFIANTI 50Hz  
 COMPRESSOR/BLOWERS SELECTION CHART 50Hz  
 DIAGRAMME DE SELECTION COMPRESSION/MOTEURS 50Hz



DIAGRAMMA DI SELEZIONE POMPE PER VUOTO/ASPIRATORI 50Hz  
 VACUUM PUMP/EXHAUSTER SELECTION CHART 50Hz  
 DIAGRAMME DE SELECTION DEPRESSION/MOT 50HzEURS



TABELLA DI SELEZIONE COMPRESSORI/SOFFIANTI 50Hz-TABLEAU DE SELECTION COMPRESSION/MOTEURS 50Hz-IMPRESSORS BLOWERS SELECTION LIST 50Hz

N° CURVA Curve n° Courbe n°	TIPO Type	kW	VOLT	Hz	A	dB	dB con silenziatore with silencer avec silenceux	Kg	Portata d'aria Air volume debit max m³/h	compressione compression max mBar	µF	Phase
1A	GKL30	0.1	Y 400	50	0.44	63		5.7	40	40		3
3B	GKL70	0.37	Y 400	50	1.00	66		9.0	78	135		3
4A	GKL100	0.74	Y 400	50	1.80	67		13.0	150	140		3
5B	GKL130	1.1	Y 400	50	2.60	74		17.5	216	180		3
5C	GKLN130	1.5	Y 400	50	3.40	74		18.0	216	220		3
6B	GKL250	2.2	Y 400	50	4.60	73		26.0	320	220		3
6C	GKLN250	3.0	Y 400	50	6.30	73		29.0	320	280		3
8C	GKL400	5.5	Y 400	50	10.90	80		61.0	480	300		3
8AF	GKL800	7.5	Δ 400	50	15.20	80		85.0	780	150		3
3AS	GKLDV70	0.77	Y 400	50	1.90	82	69	15.0	80	240		3
4AS	GKLDV100	1.55	Y 400	50	3.40	84	70	23.0	150	325		3
5BS	GKLDV130	3.0	Y 400	50	6.30	85	74	36.0	216	420		3
6BS	GKLD250	4.0	Y 400	50	8.10	88	81	42.3	320	390		3
8AS	GKLDV400	7.5	Δ 400	50	15.20	92	85	85.0	480	350		3

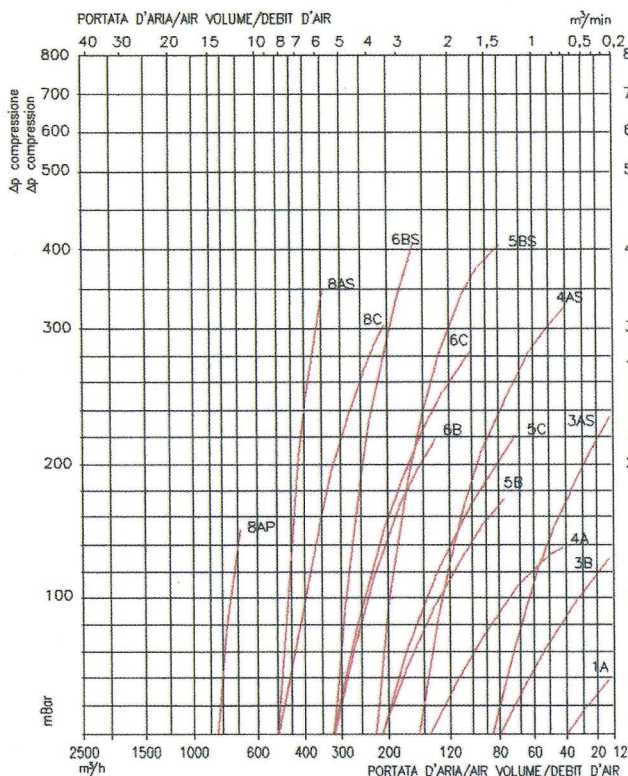
MONOPHASE

1A	GKL30	0.1	230	50	1.14	63		5.7	40	40	8	1
3B	GKL70	0.37	230	50	3.00	66		9.2	78	135	12.5	1
4A	GKL100	0.74	230	50	5.70	67		15.2	130	135	25	1
5B	GKL130	1.1	230	50	7.60	74		19.0	200	135	32	1
5C	GKLN130	1.5	230	50	9.60	74		23.6	200	170	40	1
6B	GKL250	2.2	230	50	14.70	73		29.0	280	180	50	1

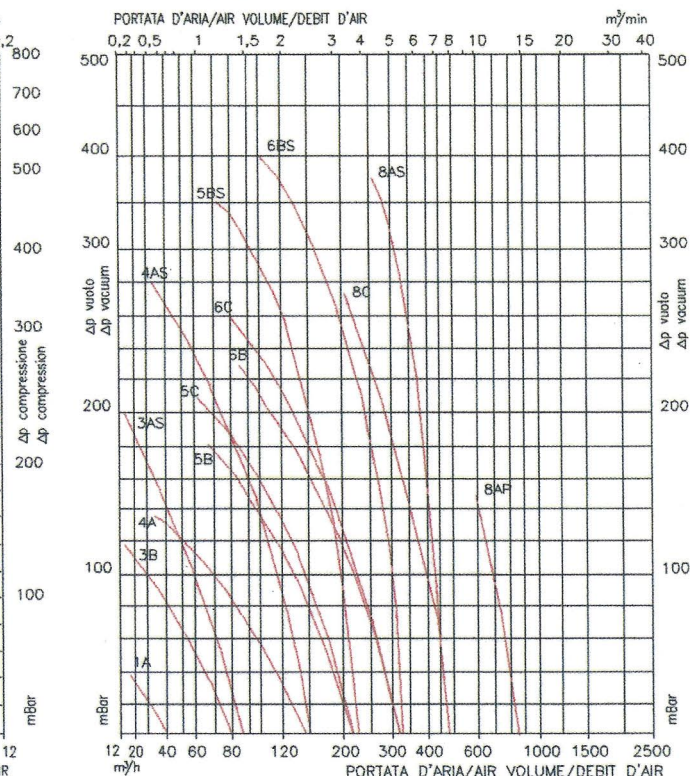
TABELLA DI SELEZIONE POMPE PER VUOTO/ASPIRATORI 50Hz-VACUUM PUMP/EXHAUSTERS SELECTION LIST 50Hz-TABLEAU DE SELECTION DEPRESSION/MOTEURS 50Hz

N° CURVA Curve n° Courbe n°	TIPO Type	kW	VOLT	Hz	A	dB	dB con silenziatore with silencer avec silenceux	Kg	Portata d'aria Air volume debit max m³/h	compressione compression max mBar	µF	Phase
1A	GKL30	0.1	Y 400	50	0.44	63		5.7	40	40		3
3B	GKL70	0.37	Y 400	50	1.00	66		9.0	78	120		3
4A	GKL100	0.74	Y 400	50	1.80	67		13.0	150	140		3
5B	GKL130	1.1	Y 400	50	2.60	74		17.5	216	180		3
5C	GKLN130	1.5	Y 400	50	3.40	74		18.0	216	210		3
6B	GKL250	2.2	Y 400	50	4.60	73		26.0	300	230		3
6C	GKLN250	3.0	Y 400	50	6.30	73		29.0	300	260		3
8C	GKL400	5.5	Y 400	50	10.90	80		61.0	480	270		3
8AF	GKL800	7.5	Δ 400	50	15.20	80		85.0	850	150		3
3AS	GKLDV70	0.77	Y 400	50	1.90	82	69	15.0	80	200		3
4AS	GKLDV100	1.55	Y 400	50	3.40	84	70	23.0	150	280		3
5BS	GKLDV130	3.0	Y 400	50	6.30	85	74	36.0	216	350		3
6BS	GKLD250	4.0	Y 400	50	8.10	88	81	42.3	300	380		3
8AS	GKLDV400	7.5	Δ 400	50	15.20	92	85	85.0	480	350		3

MONOPHASE

1A	GKL30	0.1	230	50	1.14	63		5.7	40	40	8	1
3B	GKL70	0.37	230	50	3.00	66		9.2	78	100	12.5	1
4A	GKL100	0.74	230	50	5.70	67		15.2	130	150	25	1
5B	GKL130	1.1	230	50	7.60	74		19.0	200	130	32	1
5C	GKLN130	1.5	230	50	9.60	74		23.6	200	150	40	1
6B	GKL250	2.2	230	50	14.70	73		29.0	280	180	50	1

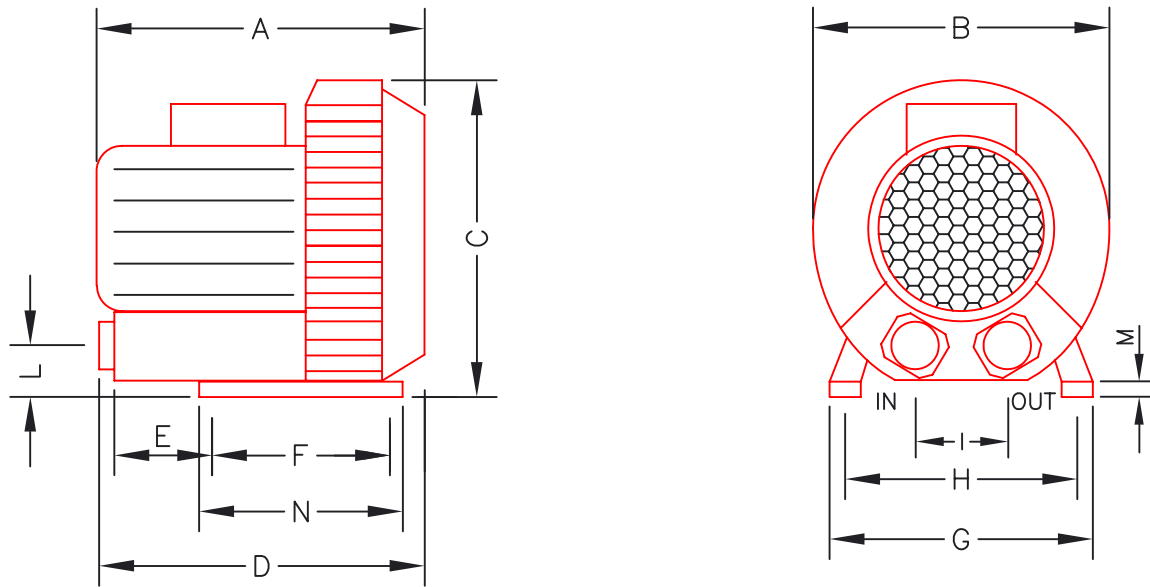

### Soplantes 3 etapa tipo GSL/Blowers three-phase type GSL

			Soplantes tipo/Frecuencia Blowers type/Frequency							
			GSL 70 50Hz	GSL 70 60Hz	GSL 100 50Hz	GSL 100 60Hz	GSL 200 50Hz	GSL 200 60Hz	GSL 250 50 Hz	GSL 250 60 Hz
Caudal nominal	<i>Displacement</i>	m <sup>3</sup> /h	80	100	145	180	210	250	210	250
Massima pressione	<i>Max pressure</i>	mbar	+95	+130	+180	+180	+220	+200	+270	+250
Nivel de ruido	<i>Noise level</i>	db (A)	69	68	69	72	72	73	72	73
Voltaje estándar	<i>Standard voltage</i>	V	230/400	240/440	230/400	240/440	230/400	240/440	230/400	240/440
Potencia del motor	<i>Motor power</i>	kW	0,38	0,42	0,9	1,15	1,5	1,75	2,2	2,55
Peso	<i>Weight</i>	kg	13	13	16	16	23,5	23,5	26	26
Conexión de entrada	<i>Inlet connection</i>		1¼"GAS	1¼"GAS	1½"GAS	1½"GAS	2"GAS	2"GAS	2"GAS	2"GAS
			1¼"GAS	1¼"GAS	1½"GAS	1½"GAS	2"GAS	2"GAS	2"GAS	2"GAS

Dimensiones (mm) <i>Dimensions (mm)</i>	A	256	256	261	261	317	317	317	317
	B	250	250	286	286	333	333	333	333
	C	257	257	303	303	345	345	345	345
	D	279	279	238	238	389	389	389	389
	E	117	117	68	68	143	143	143	143
	F	83	83	95	95	115	115	115	115
	G	230	230	255	255	296	296	296	296
	H	205	205	225	225	260	260	260	260
	I	100	100	115	115	120	120	120	120
	L	38	38	46	46	48	48	48	48
	M	12	12	3	3	4	4	4	4
	N	110	110	130	130	155	155	155	155